



Rasmussen
THE GAS LOG COMPANY

Custom Pan Burner

12028 E. Philadelphia St. Whittier, CA 90601 U.S.A.
(562) 696-8718 FAX (562) 698-3510
E-Mail: gaslogs@riwinc.com Web http://www.riwinc.com

GENERAL INSTALLATION INSTRUCTIONS

ASSEMBLY, INSTALLATION, AND OPERATION INSTRUCTIONS FOR RASMUSSEN
VENTED CUSTOM PAN BURNER MODELS:

CS; CS-W (Wide) for use with Natural Gas
CA; CA-W (Wide) for use with Propane (LP) Gas

IMPORTANT READ THESE INSTRUCTIONS CAREFULLY BEFORE
STARTING INSTALLATION OF LOG SET.

WARNING: Improper installation, alteration, service or maintenance can cause injury or property damage. Read these instructions thoroughly before installation. For assistance or additional information, consult your gas log dealer, qualified installer, service agency or gas supplier.

FOR YOUR SAFETY

Do not store or use gasoline or other flammable vapors and liquids in the vicinity of this or any other appliance.

FOR YOUR SAFETY

WHAT TO DO IF YOU SMELL GAS

- Do not try to light any appliance.
- Do not touch any electrical switch; do not use any phone in your building.
- Immediately call your gas supplier from a neighbors phone. Follow the gas suppliers instructions.
- If you cannot reach your gas supplier, call the fire department.

IMPORTANT INFORMATION

**THIS GAS LOG SET MUST BE INSTALLED IN A FULLY VENTED
SOLID-FUEL BURNING FIREPLACE WITH A WORKING FLUE
CONSTRUCTED OF NON COMBUSTIBLE MATERIAL.**

The minimum permanent free opening of the fireplace chimney or chimney damper must be at least 39 square inches based on a minimum chimney height of at least 8 feet. The area of the flue must not be less than 1/10 the area of the fireplace opening. **The flue must exhaust all products of combustion.**

The chimney damper must be fixed in a manner to maintain permanent free opening as outlined above at all times. To accomplish this, install the damper clamp (provided) on the edge of the damper blade to prevent its closing, drill a hole or holes in the damper, or remove damper completely.

The minimum size of the fireplace in which the log set is to be installed must be as follows:

MINIMUM FIREPLACE SIZE IN INCHES

LOG SET SIZE	HEIGHT	DEPTH	WIDTH	CHIMNEY
18 INCH	16	13	24	7 INCH DIAMETER
24 INCH	16	13	32	7 INCH DIAMETER
30 INCH	16	13	36	8 INCH DIAMETER

**Glass doors must be wide open when burner is lighted
to allow air for safe combustion and venting.**

**THIS BURNER IS FOR USE IN FULLY FUNCTIONING WOOD BURNING
FIREPLACE WITH THE DAMPER WIDE OPEN.
THE FLUE MUST VENT ALL PRODUCTS OF COMBUSTION.**

IMPORTANT INFORMATION (continued)

A fire place screen must be in place when the log set is in operation and, unless other provisions for combustion air are provided, the screen shall have opening(s) for introduction of combustion air.

The minimum inlet gas supply pressure for the purpose of input adjustment shall be 6 inches of water column on natural gas and 11 inches of water column on propane gas.

The maximum inlet gas supply pressure shall be 7 inches of water column on natural gas and 14 inches of water column on propane gas..

The installation and the provision for combustion and ventilation air must conform with the NATIONAL FUEL GAS CODE ANSI Z223.1 latest edition.

The gas log set and its individual shutoff valve must be disconnected from the gas supply piping system during any pressure testing of that system at test pressures in excess of 1/2 psig (3.5 kPa). The gas log set must be isolated from the gas supply piping system by closing its individual manual shutoff valve during any pressure testing of the gas supply piping system at test pressures equal to or less than 1/2 psig (3.5 kPa).

The area around the gas log set must be clear and free from combustible materials, gasoline and any other flammable vapors and liquids.

Do not use this appliance if any part has been under water. Immediately call a qualified service technician to inspect the appliance and to replace any part of the control system and any gas control which has been under water.

WARNING: A SAFETY PILOT MUST BE INSTALLED ON ALL UNITS DESIGNED OR CONVERTED TO BURN PROPANE/LP GAS

When used with LP Gas, ensure that the Burner Pan is filled with the BLACK VOLCANIC ASH supplied with the Burner.

WARNING: CARBON MONOXIDE POISONING MAY LEAD TO DEATH

When used without fresh air, gas log set may give off carbon monoxide, an odorless, colorless, poisonous gas.

Some people - pregnant women, persons with heart or lung disease, anemia, or under the influence of alcohol and persons at high altitudes are more affected by carbon monoxide than others.

Early signs of carbon monoxide poisoning resemble the flu: Headache, dizziness, and/or nausea. If you have these signs, the gas log may not be installed or working properly, or the chimney flue may be blocked. **GET FRESH AIR AT ONCE!** Have gas log set and chimney flue serviced before using again.

**DAMPER MUST BE WIDE OPEN WHILE BURNING
OPEN A WINDOW AN INCH OR TWO FOR
FRESH AIR WHEN USING YOUR GAS LOG
SOLID FUELS SHALL NOT BE BURNED IN A FIREPLACE
WHERE A DECORATIVE APPLIANCE IS INSTALLED.**

WARNING: If not installed, operated and maintained in accordance with these instructions, this product could expose you to substances in fuel or from fuel combustion which are known to the State of California to cause cancer, birth defects or other reproductive harm.

WARNING! CHECK FOR PROPER VENTING

A properly sized, unobstructed chimney will normally vent all fumes and products of combustion. Any odor or smoke detected inside the room is an indication that the flue is not properly removing the combustion products.

SHUT OFF THE BURNER IMMEDIATELY! THE CAUSE OF THE VENTING PROBLEM MUST BE DISCOVERED AND CORRECTED BEFORE CONTINUED USE OF THE GAS LOG SET.

Continued use with improper venting may cause damage to your fireplace, room and furnishings and could cause serious illness. If improper venting is suspected, **IMMEDIATELY HAVE LOG SET AND CHIMNEY FLUE SERVICED.**

Periodically examine and clean the venting system. Once a year, a qualified agency should examine and clean the venting system of your solid fuel burning fireplace.

ATTENTION

READ THESE INSTRUCTIONS CAREFULLY BEFORE ASSEMBLY

REQUIRED TOOLS AND MATERIALS: Screw Driver, Adjustable Wrench, Pipe Wrench, Pipe Sealing Compound, Matches.

PREPARATION:

1. This Gas Log set must be **INSTALLED IN A FULLY VENTED METAL OR MASONRY FIREPLACE WITH A WORKING FLUE THAT IS SAFE FOR BURNING A WOOD FIRE.** The Flue **MUST BE FREE OF ANY OBSTRUCTIONS.**
2. Turn off gas supply to fireplace.
3. Clean fireplace floor of any ashes.
4. Attach damper clamp over edge of fireplace damper blade as shown at Figure 1. When installed properly, damper clamp prevents accidental full closure of damper. If unable to install provided damper clamp, consult **IMPORTANT INFORMATION** on front page of these directions.

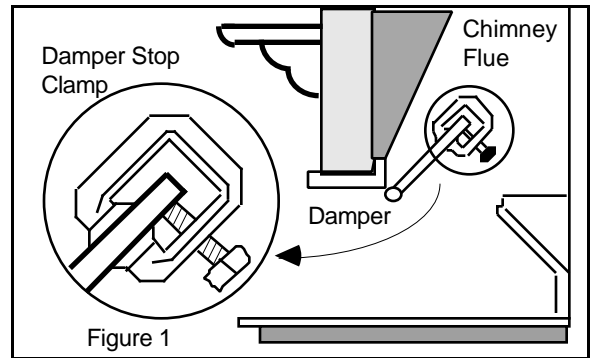

STEP ONE: Burner Pan Assembly.

Attaching Burner Pan Legs (All Applications)

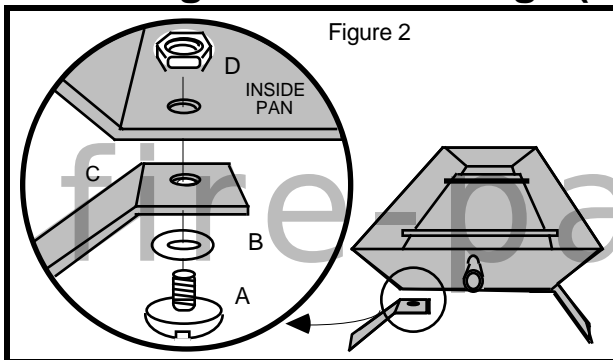

1. Place **FIBER WASHER (B)** onto **BOLT (A)**. Insert **BOLT (A)** with **FIBER WASHER (B)** through the pre-drilled hole in **LEG (C)**.
2. Attach **LEG (C)** through pre-drilled hole at outside-bottom corner of **BURNER PAN** with **NUT (D)**. Wrench tighten **NUT (D)** securely to ensure mechanical strength and a tight gas seal. Repeat for all four legs. See Figure 2.

NOTE: In extremely low fireplaces or where andirons are being used, the **LEGS** may be left off. **HOWEVER, TO PREVENT GAS LEAKING BENEATH THE BURNER PAN, THE NUT-BOLT AND FIBER WASHER MUST BE INSTALLED TO ENSURE GAS TIGHT INTEGRITY.**

Standard Match Lighted

- (For use only with **Natural Gas Models CS, CS-W**)

WARNING: A SAFETY PILOT MUST BE INSTALLED ON ALL UNITS DESIGNED OR CONVERTED TO BURN PROPANE/LP GAS

1. Apply pipe compound to threaded end of **3/8" FLARED BRASS ELBOW (A)**. Do not apply pipe compound to flared end. Thread into **BURNER PAN INLET (B)** and wrench tighten. See Figure 3

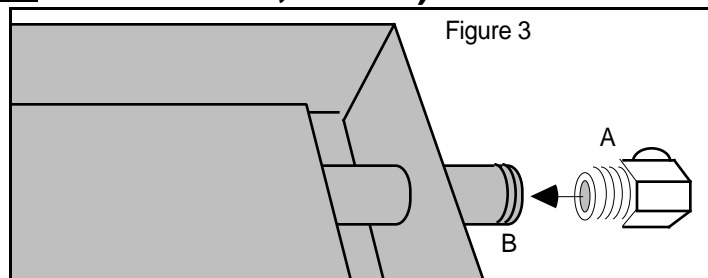

Accessory Match Lighted Manual V17B Valve

- (For use only with **Natural Gas Models CS, CS-W**)

WARNING: A SAFETY PILOT MUST BE INSTALLED ON ALL UNITS DESIGNED OR CONVERTED TO BURN PROPANE/LP GAS

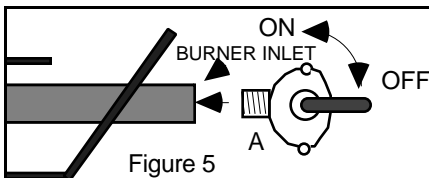
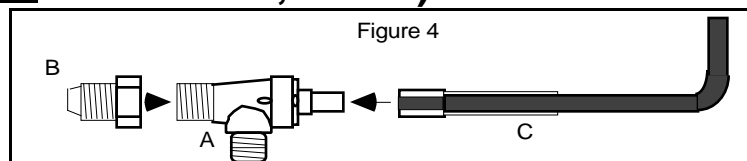

1. Apply pipe compound to the 3/8" inlet threads of **V-17 VALVE (A)** body. Thread brass **CONNECTOR FITTING (B)** onto inlet threads of **V-17 VALVE (A)** body and wrench tighten. Insert **VALVE HANDLE (C)** over **V-17 VALVE STEM**. See Figure 4 .
2. Apply pipe compound to the 3/8" outlet threads of **V-17 VALVE (A)** body. Thread into **BURNER INLET** and wrench tighten. See Figure 5.

Accessory Safety Pilot Lighting Kit SPK3:

- **SPK3-CS** (For use with Natural Gas Models CS, CS-W)
- **SPK3-CA** (For use with Propane Gas Models CA, CA-W)

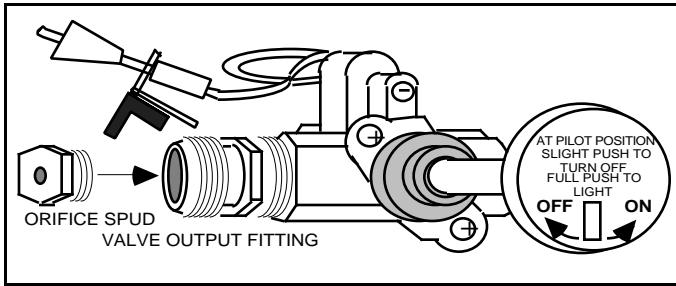

Figure 6

A. Insert Burner Orifice.

1. Thread **ORIFICE SPUD** into **VALVE OUTPUT FITTING** and wrench tighten. **DO NOT USE PIPE COMPOUND WHEN INSERTING ORIFICE.** See Figure 6.

NOTE: Maximum flame height can be adjusted by changing orifice size, e.g., a larger orifice results in a larger flame.

SUGGESTED ORIFICE SIZES				
BURNER SIZE	18"	24"	30"	36"
NAT. GAS ORIFICE SIZE	#36	#28	#28	#25
LP. GAS ORIFICE SIZE	#53	#49	#45	#42

B. Attach Valve to Burner Pan.

1. Apply Pipe Compound to outside threads of **BURNER PAN INLET**. Thread **BURNER PAN AIR MIXER (CA/CA-W)** or **BURNER PAN REDUCING COUPLING (CS/CS-W)** onto **BURNER INLET** and wrench tighten. See Figure 7.

2. Apply Pipe Compound to outside threads of the **VALVE OUTPUT FITTING**. Do not allow pipe compound to clog orifice. Insert **VALVE** into **BURNER PAN AIR MIXER (CA/CA-W)** or **BURNER PAN REDUCING COUPLING (CS/CS-W)** and using wrench placed onto **VALVE** at the **WRENCH ATTACH POINT**, tighten to the position shown at Figure 7.

C. Attach Pilot-Thermocouple

1. Align the **PILOT-THERMOCOUPLE ASSEMBLY** on side of **BURNER PAN** as shown in Figure 7. Using **NUT** and **BOLT** through pre-punched hole in side of burner pan, attach **ANGLE BRACKET** ensuring that the **PILOT BURNER** is located beyond the side and inside the **BURNER PAN**. See Figure 8 below.

ATTENTION: To ensure correct operation of the **PILOT**, the **THERMOCOUPLE LEAD** and **PILOT TUBING** should be coiled away from the **BURNER PAN**.

Figure 8

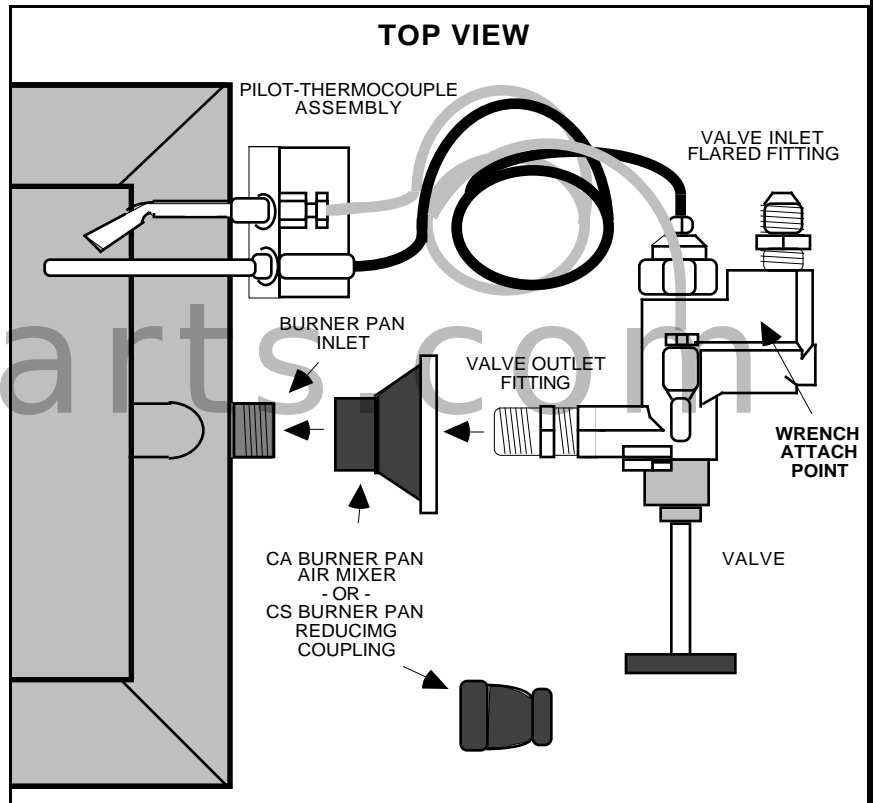
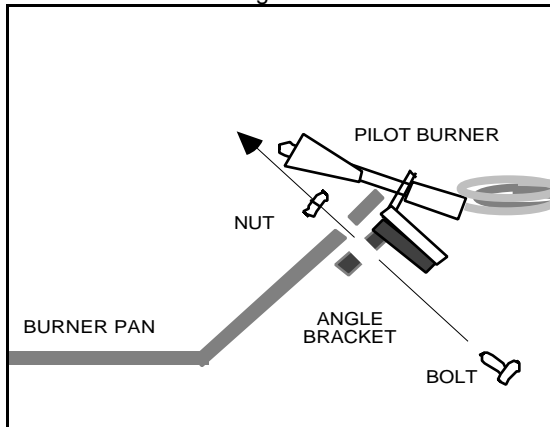

Figure 7

D. Install Heat Shield.

1. With the notched end over the **VALVE OUTPUT FITTING**, place the **HEAT SHIELD** over the **VALVE** as shown in Figure 9.

WARNING: HEAT SHIELD MUST BE INSTALLED TO PREVENT PREMATURE VALVE FAILURE AND/OR VOIDING OF VALVE MANUFACTURER'S WARRANTY

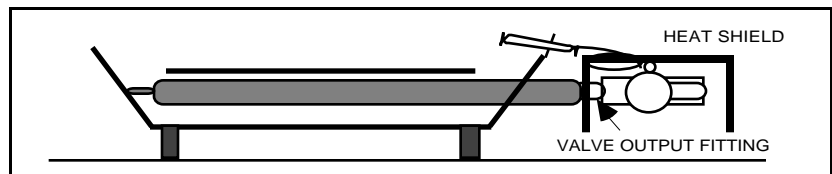

Figure 9

STEP TWO: Burner Pan Positioning.

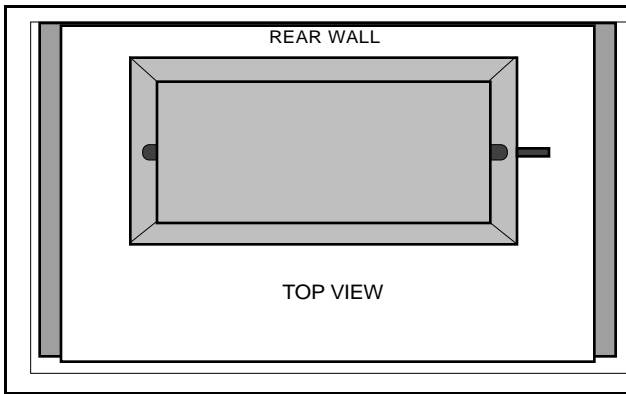

Figure 10

1. Place **BURNER PAN** inside firebox as far to the rear as possible. Then center **BURNER PAN** left to right.

See Figures 10 and 11.

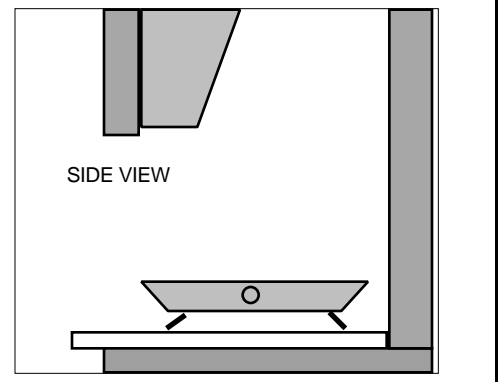

Figure 11

STEP THREE: Gas Supply Connection.

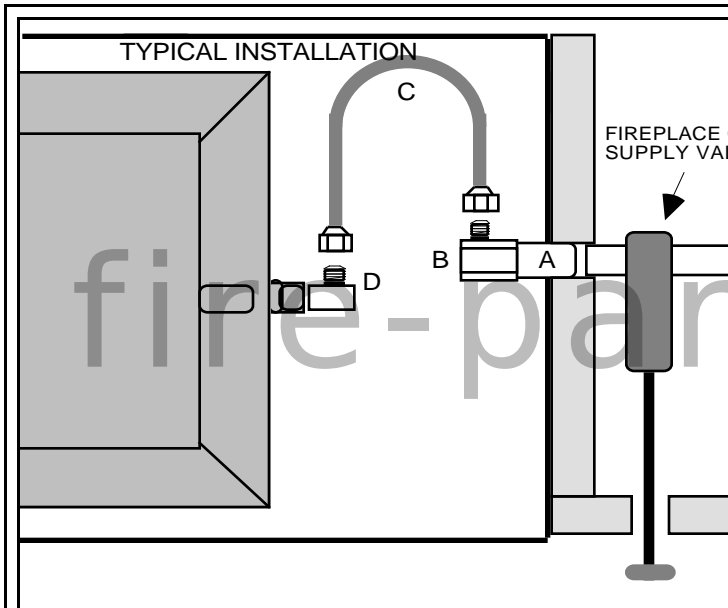

Figure 12

ENSURE THAT GAS SUPPLY TO FIREPLACE IS TURNED OFF

1. Apply pipe compound to threaded end of **GAS SUPPLY PIPE (A)**. Thread **1/2" FIP x 3/8" FLARE ELBOW (B)** onto **GAS SUPPLY PIPE (A)** and wrench tighten. See Figure 12.

2. With **BURNER PAN** inside firebox at previously marked position, thread (without pipe compound) one end of the **ALUMINUM CONNECTOR TUBE (C)** to the **1/2" FIP x 3/8" FLARE ELBOW (B)** and wrench tighten.

3. Carefully bending **ALUMINUM CONNECTOR TUBE (C)**, align and connect, without pipe compound, to the **FLARED BURNER INPUT FITTING (D)**. Wrench tighten. Figure 12

NOTE: If bent into too small a radius the **ALUMINUM CONNECTOR TUBE (C)** may kink or break, causing air flow noise and/or leaks.

4. Turn gas supply to fireplace on.

5. Test all connections for leaks with soapy water solution. If solution bubbles, turn off gas supply, re-tighten fitting and recheck.

WARNING: DO NOT FLAME TEST FOR LEAKS.

STEP FOUR: White Sand, Black Volcanic Ash and Ember Magic Placement.

1. Completely fill **BURNER PAN**, including underneath the **BAFFLE PLATE**, with the appropriate **PAN MEDIUM**. The **WHITE SAND** is for use with Natural Gas, the **BLACK VOLCANIC ASH** is for use with Propane/LP Gas. Use the **ENTIRE CONTENTS** of the bag provided with the burner. Be sure to completely cover **BURNER TUBE**. See Figure 13.

2. Sprinkle a light covering of "**EMBER MAGIC**" over the **PAN MEDIUM**. Pull apart "**EMBER MAGIC**" fiber material to enhance the glowing ember effect.

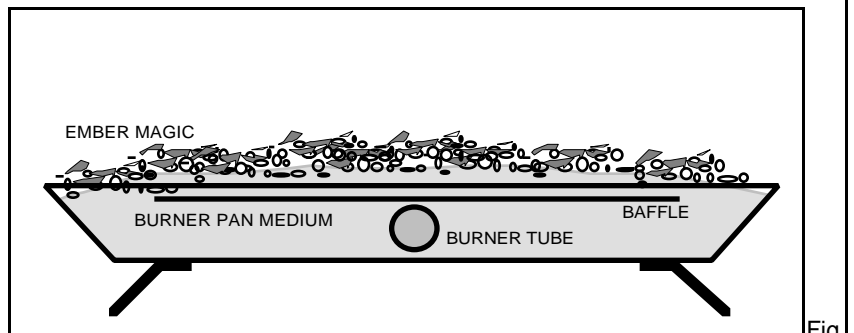
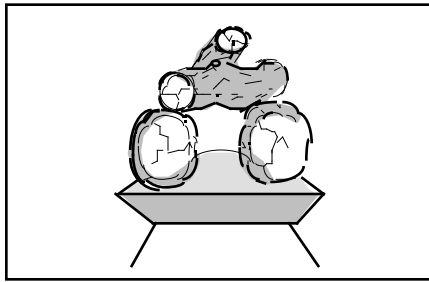
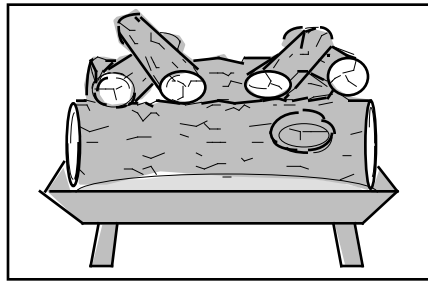

Figure 13

STEP FIVE: Log Placement.



SIDE VIEW



FRONT VIEW

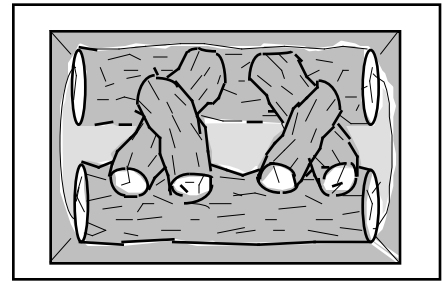

TOP VIEW

(1) **LOG SET.** Place large **LOGS** on filled **BURNER PAN**. Allow 2" to 3" space between front and rear logs. Lay smaller logs on bottom in cross position. **CAUTION:** Crowded logs will cause poor combustion and result in excessive soot formation.

(2) **DRIFTWOOD** or **MANZANITA STUMP.** Stand large **DRIFTWOOD** or **STUMP** piece slightly ahead of center on filled **BURNER PAN**. Surround with **EMBER MAGIC** to simulate burned embers. Large pieces of **EMBERS** should be inserted 1/2" into **PAN MEDIUM** for best effect. On larger sets, arrange companion pieces to fill up balance of burner.

(3) **PINE CONE SET** or **FIREBALLS.** Mound **EMBER MAGIC** in middle of **PAN**. Place large **PINE CONES** or **FIRE BALLS** around edge of **BURNER** and over mound of **EMBER MAGIC**. Fill in gaps with smaller **PINE CONES**.

STEP SIX: Lighting Instructions and Operation.

IMPORTANT: CHIMNEY DAMPER MUST BE WIDE OPEN

MANUAL MATCH LIGHTING.

• Standard Match Lit Set (Applies only to Natural Gas Models CS or CS-W)

1. Place lighted match on embers near inlet end of burner. **DO NOT HOLD MATCH IN HAND!** Move away from front of fireplace.
2. Slowly open **FIREPLACE GAS SUPPLY VALVE** and wait for burner to light. (See FIGURE 7)
3. Adjust **FIREPLACE GAS SUPPLY VALVE** for desired flame height.
4. **SHUTDOWN:** Close **FIREPLACE GAS SUPPLY VALVE** completely.

MANUAL MATCH LIGHTING WITH ACCESSORY V17 VALVE.

• Match Lighted V17 Valve (Applies only to Natural Gas Models CS or CS-W)

1. Ensure that **MANUAL V17 VALVE** is completely closed. (See FIGURE 5)
2. Open **FIREPLACE GAS SUPPLY VALVE**. (See FIGURE 7)
3. Place lighted match on embers near inlet end of burner. **DO NOT HOLD MATCH IN HAND!**
4. Slowly open **MANUAL V17 VALVE** and wait for burner to light.
5. Adjust **MANUAL V17 VALVE** for desired flame height.
6. **SHUTDOWN:** Close **MANUAL V17 VALVE** and **FIREPLACE GAS SUPPLY VALVE** completely.

PILOT LIGHTING USING ACCESSORY SPK3.

- **SPK3-CS** (Applies to Natural Gas Models CS or CS-W)
- **SPK3-CA** (Applies to Propane/LP Gas Models CA or CA-W).

SPK-3CS/CA LIGHTING INSTRUCTIONS.

1. Bleed all air from piping leading to control. Carefully re-tighten connection.
2. Turn **CONTROL KNOB** pointer to "OFF" position. Wait 5 minutes before lighting.
3. Turn **CONTROL KNOB** pointer to "PILOT" position. Depress **CONTROL KNOB** and hold down 60 seconds after lighting pilot burner. Release **CONTROL KNOB**. Pilot will remain lighted.
4. Turn **CONTROL KNOB** partially towards the "ON" position. After gas fills burner pan medium, burner will light. Dial may then be turned to full "ON" or to desired flame height.
5. If main or pilot burner extinguishes, turn **CONTROL KNOB** to "OFF" position. Wait five minutes and repeat above lighting procedure from step 1.

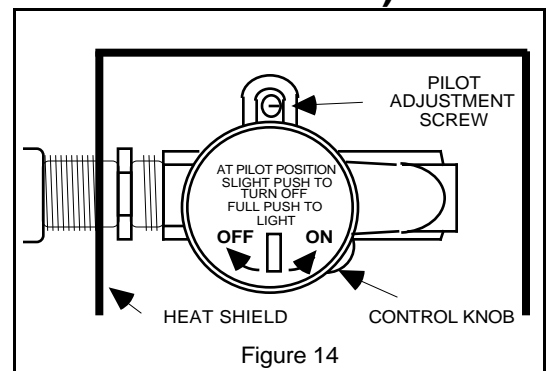

PILOT LIGHTING USING ACCESSORY SPK3. (Continued)

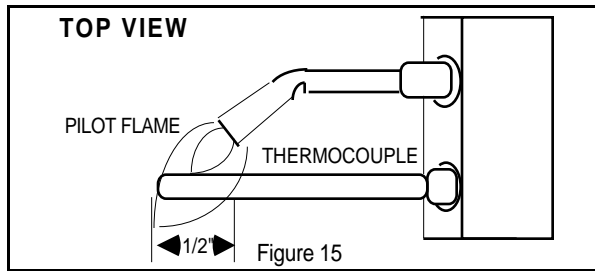

SPK3-CS/CA PILOT FLAME ADJUSTMENT INSTRUCTIONS.

1. Adjust Pilot if necessary. With narrow long stem screw driver, turn **PILOT ADJUSTMENT SCREW** clockwise to reduce size of pilot flame or counterclockwise to increase flame.

Correctly adjusted pilot flame should be steady and soft blue surrounding approximately 1/2 inch of thermocouple tip. Never permit tip to exceed a dull red temperature. (See Figure 6)

SPK3-CS/CA VALVE SPECIFICATIONS.

Maximum valve operating pressure is 1/2 PSI (14" WC)
Maximum valve capacity is 129,000 BTU

Maximum ambient temperature is 300° F
AGA certified to ANSI Z 21.20 and ANSI Z 21.15

SPK3-CS/CA SERVICE AND TROUBLESHOOTING.

Analysis and correction of control service problems must be made by qualified gas service men only. Attempts to service or repair the Safety Pilot by other than authorized service personnel will void the manufacturer's responsibility and guarantee. In general, failure of control to operate may be due to the reasons noted below:

1. Pilot will not light initially:
 - Check for loose thermocouple Terminal Nut connection.
 - Check for improper pilot flame adjustment.
 - Check that Dial is fully depressed during pilot lighting operation and held depressed for 60 seconds after lighting.
 - Check for defective thermocouple.
 - Check for defective thermo magnet unit.
2. Pilot / main burner clicks off after 5 to 30 minutes of burning:
 - Valve and thermocouple are not defective, otherwise pilot would not initially light.
 - Thermocouple is losing temperature difference between hot tip and cold junction (base).
 - Check that thermocouple assembly is installed on side of burner on bracket per instructions.
 - Check that only tip of thermocouple is in main burner flame.
 - Remove then replace logs to alter heat radiation pattern. Ensure that glass doors are open.
 - Ensure that proper size gas log set is installed. Too large of a set decreases cooling air flow.

ACCESSORY RPK1, RPK1-F10 or RMC1

- **RPK1-CS, RPK1-F10-CS or RMC1-CS**
(Applies to Natural Gas Models CS OR CS-W).
- **RPK1-CA, RPK1-F10-CA or RMC1-CA**
(Applies to Propane/LP Gas Models CA OR CA-W).

See detailed instructions included with **Safety Pilot Lighting Kits RPK1-CS/CA, RPK1-F10-CS/CA, or RMC1-CS/CA SAFETY PILOT LIGHTING KITS.**

CUSTOMER MAINTENANCE:

THIS BURNER IS FOR USE FOR USE IN A FULLY FUNCTIONING WOOD BURNING FIREPLACE WITH THE DAMPER WIDE OPEN. THE FLUE MUST VENT ALL PRODUCTS OF COMBUSTION..

Periodically examine and clean the venting system. Once a year, a qualified agency should examine and clean the venting system of your solid fuel burning fireplace.

Periodically check the pilot burner (if equipped) and main burner flames. The pilot burner should be free of lint and dirt for best performance. The main burner should produce a relatively even flame from side to side. If not, the sand-granules may have become packed and can be loosened by working a wire or knife blade under the sand or by refilling the pan as described in section four.

PARTS LIST:

- | | | |
|-----------------------|--|---|
| - Burner Pan | - Brass Connector Fitting | - Logs: Specify Front, Rear or Top and style/size and shape (Top logs). |
| - Burner Pan Legs (4) | - Damper Stop Clamp (DC1) | - Instructions |
| - Fiber Washers (4) | - Ember Magic | - Pan Filler: White Sand (Natural Gas-CS) With CA or CA-Wide |
| - Nuts/Bolts (4 each) | - Pan Filler: Black Volcanic Ash (LP Gas-CA) | - Mixer Assembly (MA) |
| - Connector Tube | | |

LIMITED LIFETIME CONSUMER PRODUCT WARRANTY

The following warranty has been drafted to comply with the MAGNUSON-MOSS WARRANTY ACT applicable to products manufactured after July 4, 1975. It replaces and supersedes any warranty in this package or in any printed literature.

LIMITED WARRANTY:

RASMUSSEN IRON WORKS INC, 12028 E. Philadelphia Street, Whittier California, U.S.A., warrants this Gas Log Set and accessories against defects in materials and workmanship, and suitable for a particular purpose, for a period of:

- (1) LOG CASTING - All logs are guaranteed against burnout in the original installation for the lifetime of the initial purchaser.
- (2) BURNERS/GRATES - 2 years from date of purchase.
- (3) SAFETY CONTROLS - Pilots and safety controls are covered by warranty of the original manufacturer only.

THIS WARRANTY IS FOR THE BENEFIT OF THE ORIGINAL PURCHASER.

WARRANTY ADJUSTMENT:

- (1) RASMUSSEN agrees to repair or furnish a replacement for, but not remove or install any product or component which proves defective within the above warranty and appropriate time periods stated.
- (2) BUYER shall notify RASMUSSEN of any defect within this warranty no later than thirty (30) days after a defect is discovered.
- (3) No product will be accepted for return or replacement without written authorization of RASMUSSEN. Before returning merchandise, write to RASMUSSEN giving full details of the complaint and a copy of sales receipt or other evidence of purchase date. Merchandise returned without proof of purchase date will be serviced out-of warranty at our prevailing service and parts rates. If merchandise was damaged in transit, file claim immediately with the carrier. Products returned must be addressed as follows:

RASMUSSEN IRON WORKS INC
12028 E. PHILADELPHIA STREET
WHITTIER CALIFORNIA 90601

Shipping charges must be pre-paid by the buyer. **REPAIR OR REPLACEMENT UNDER THIS WARRANTY WILL BE SHIPPED FREIGHT COLLECT.**

EXCLUSIONS FROM WARRANTY:

- (1) The foregoing warranty is limited solely as set forth herein and applies only for the periods designated above.
- (2) RASMUSSEN shall not be liable for any loss, damage, incidental or consequential damages of any kind, whether based upon warranty, contract, or negligence, arising in connection with the sale, use, or repair of the product. Some states do not allow the exclusion or limitation of incidental or consequential damages, so the above limitation or exclusion may not apply to you.
- (3) The maximum liability of RASMUSSEN in connection with this limited warranty shall not in any case exceed the contract price paid for the product claimed to be defective or unsuitable.
- (4) This warranty does not extend to any product manufactured by RASMUSSEN which has been subjected to misuse, neglect, accident, improper installation, or use in violation of instructions furnished by RASMUSSEN.
- (5) This warranty does not extend to or apply to any unit which has been repaired or altered at any place other than RASMUSSEN IRON WORKS INC factory, or by persons not expressly approved by RASMUSSEN.
- (6) Components manufactured by any supplier other than RASMUSSEN shall bear only that warranty made by the manufacturer of that product.
- (7) Freight damage, cracking from thermal shock, and color changes occur from causes beyond manufacturer's control and are not covered by any warranty.

THIS WARRANTY GIVES YOU SPECIFIC LEGAL RIGHTS, AND YOU MAY ALSO HAVE OTHER RIGHTS WHICH VARY FROM STATE TO STATE.

RASMUSSEN IRON WORKS, INC. shall be held harmless from any and all claims by the buyer as a result of injury or damage to an ultimate user or other person caused by the product sold herein by the seller to the buyer, whether the injury or damage results from the assembly, installation, operation, shipment, storage or manufacture of this product. RASMUSSEN IRON WORKS, INC. makes no warranties, expressed or implied, other than those expressly stated herein.

- CUSTOMER RESPONSIBILITY -

Your Gas Log is designed to burn with a natural smoky yellow flame that produces carbon soot. Like a wood fire, burning a Gas Log with the flue blocked or closed will cause fumes and smoke to remain in the room and cause health hazards.

DAMPER MUST BE FULLY OPEN WHEN BURNING A GAS LOG SET. Never burn wood with your gas log set as this will reduce the life of your gas Log Set and will void any warranty.

CONSUMER RECORD CARD



**FOR CUSTOMER RECORDS ONLY
DO NOT SEND THIS CARD TO MANUFACTURER**

LOG MODEL: _____

SAFETY CONTROL: _____

DATE OF PURCHASE: _____

DEALER: _____

INSTALLER: _____